

DOUBLE GIRDER, LOW CLEARANCE, 2 PART SINGLE

Hoist type:

SX5 021...DL

US-60Hz

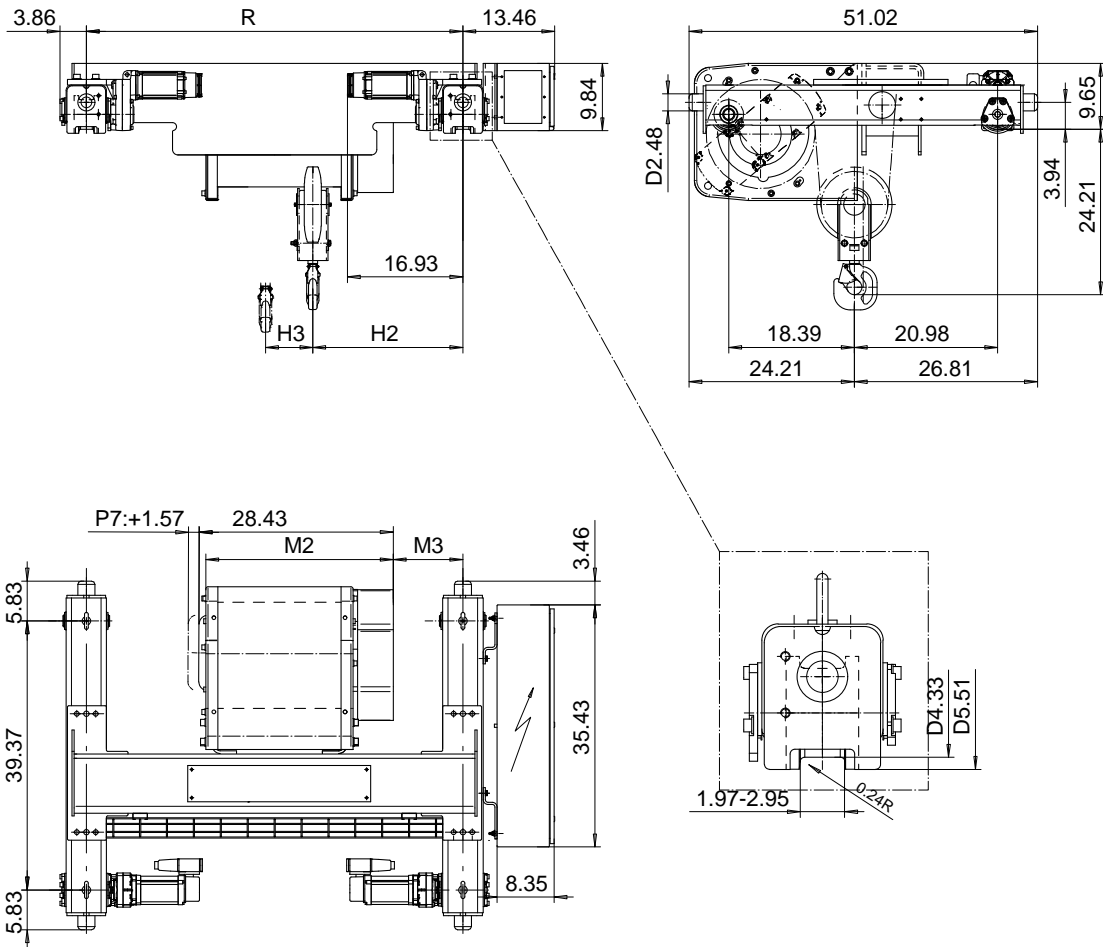

Load (TON)	Class ASME	Hoisting speed (ft/min)			
		Gear+Motor code:			
		E+P5	F+P5	H+P6	J+P7
4	H4+	30/4.9	40/6.7	60/9.8	80/12.5
5	H4	30/4.9	40/6.7	60/9.8	80/12.5
+ weight (lb):		-	-	60	80

HOL (ft)	Length code	M2 (inch)	M3 (inch)	H2 (inch)	H3 (inch)	min R (ft)	Weight (lb)
59'-0"	D	27.44	10.19	21.96	6.92	4'-7 1/8"	1300
78'-8"	E	32.16	10.19	21.96	9.25	4'-7 7/8"	1350
104'-11"	F	38.07	14.64	26.41	12.16	5'-6 7/8"	1440
131'-2"	G	45.55	20.55	32.32	15.86	6'-6 3/4"	1520

Note: minR is minimum rail gauge when second brake is supplied
Standard rail gauges are 4'-7 1/8", 5'-6 7/8", and 6'-6 3/4".

This document is the absolute property of R&M Materials Handling, Inc. This document must not be copied without the written permission of R&M Materials Handling, Inc. The contents thereof must not be disclosed to a third party nor be used for any unauthorized purpose. Contravention will be prosecuted.

ETPAL Design 2002-08-29 Date	ETPAL Chd Appd	Ref Drawing	QC-W-02
SLEQDOCV Owner Dept	TROLLEY; DOUBLE GIRDER LOW, 2 ROPE FALLS		1 of 12 Folder
R&M MATERIALS HANDLING, INC. HOIST & CRANE PRODUCTS SHELTON, CT	D002115-A		Issue 6