

DOUBLE GIRDER, HIGH CONNECTION, 6 PART DOUBLE
Hoist type:
SX5 062...DH

US-60Hz

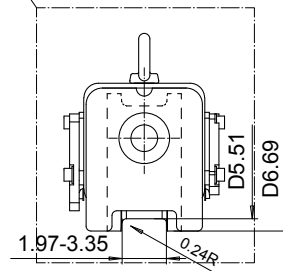
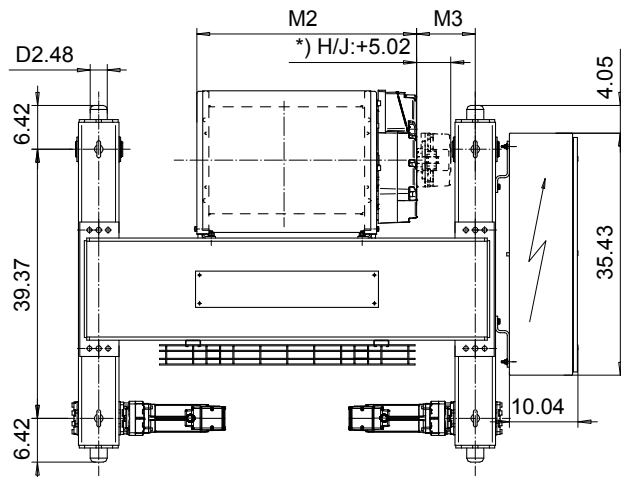
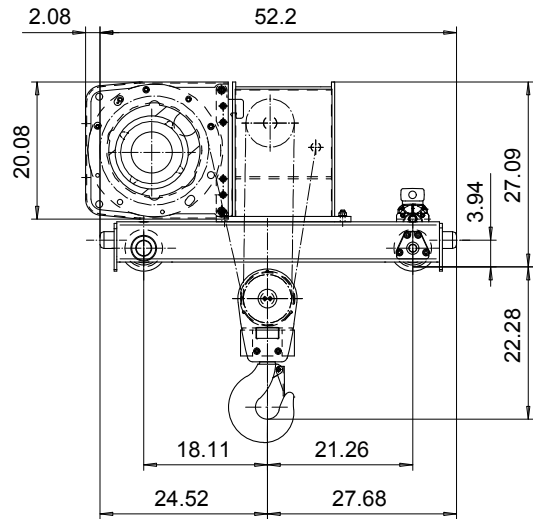
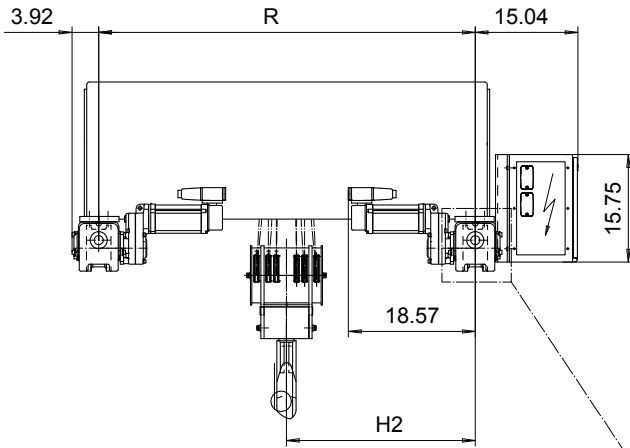

Load (TON)	Class ASME	Hoisting speed (ft/min)		
		Gear+Motor code:		
		F+P5	H+P6	J+P7
12	H4+	12.5/1.9	20/3.1	25/3.9
15	H4	12.5/1.9	20/3.1	25/3.9
+ weight (lb):		-	60	80

HOL (ft)	Length code	M2 (inch)	M3 (inch)	H2 (inch)	min R (ft)	Weight (lb)
13'-1"	E	32.16	4.60	23.81	3'-11 1/4"	1720
19'-8"	F	38.07	5.62	27.75	4'-7 1/8"	1840
26'-2"	G	45.55	7.75	33.66	5'-6 7/8"	2000
36'-1"	H	55.27	4.13	33.66	5'-6 7/8"	2090
49'-2"	J	69.17	10.07	47.67	7'-10 1/2"	2420

Note: minR is minimum rail gauge when second brake is supplied
 Standard rail gauges are 3'-11 1/4", 4'-7 1/8", 5'-6 7/8", 6'-6 3/4",
 and 7'-10 1/2".

The brake is mounted to the gearcase on drum lengths H and J

This document is the absolute property of R&M Materials Handling, Inc. This document must not be copied without the written permission of R&M Materials Handling, Inc. The contents thereof must not be disclosed to a third party nor be used for any unauthorized purpose. Contravention will be prosecuted.

ETTATA Design	ETTAV Chd	Appd	Ref Drawing	QC-H-26
2002-10-17 Date	TROLLEY; DOUBLE GIRDER			1 of 12 Folder
SLEQDCV Owner Dept	HIGH, 2x6 ROPE FALLS			
R&M MATERIALS HANDLING, INC. HOIST & CRANE PRODUCTS	D002245-A			Issue 4