

**FOOT MOUNT, 4 PART SINGLE**  
**Hoist type:**  
**SX4 041...F0**

SI-50Hz

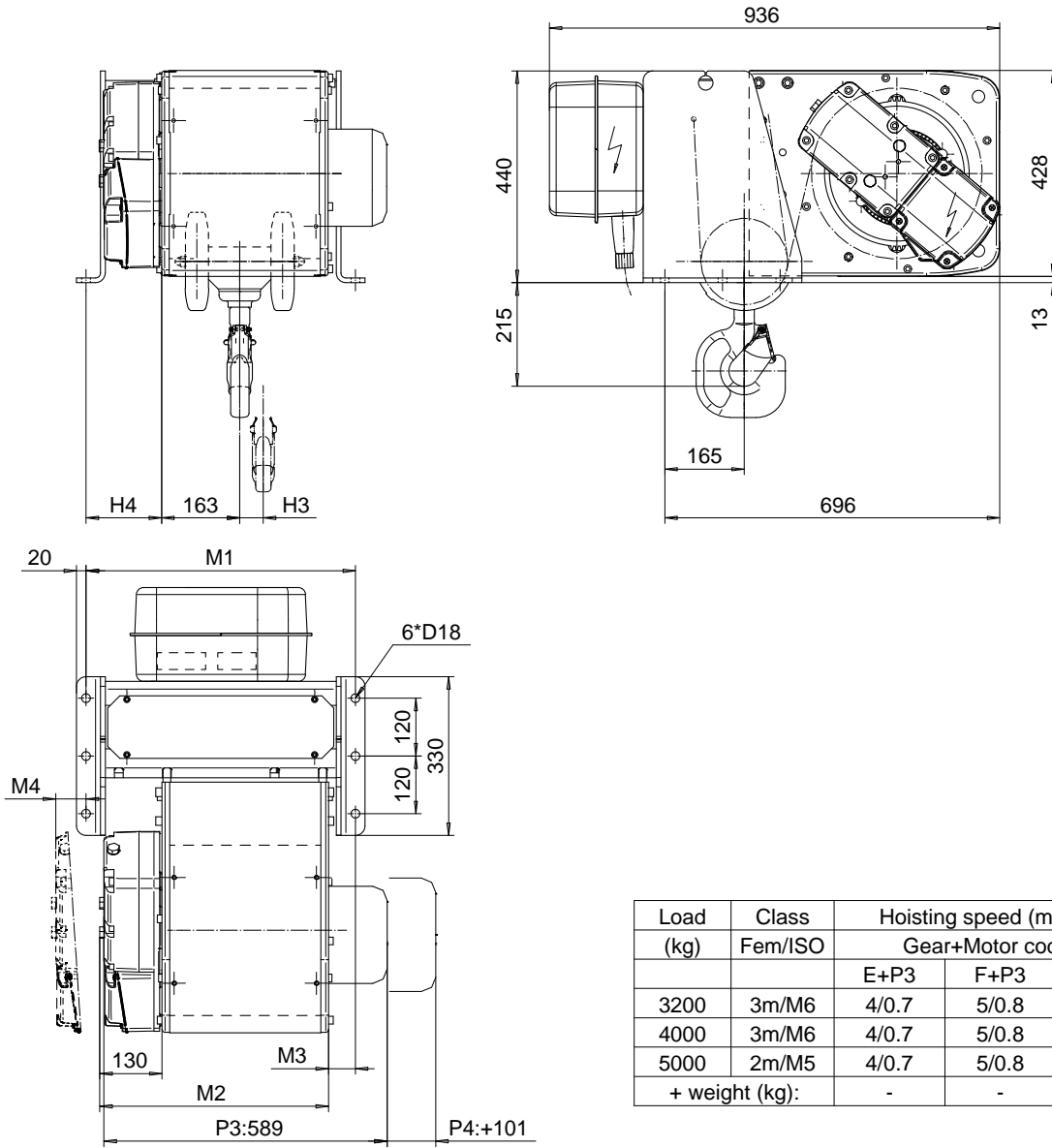

Load (kg)	Class Fem/ISO	Hoisting speed (m/min)		
		Gear+Motor code:		
		E+P3	F+P3	H+P4
3200	3m/M6	4/0.7	5/0.8	8/1.3
4000	3m/M6	4/0.7	5/0.8	8/1.3
5000	2m/M5	4/0.7	5/0.8	8/1.3
+ weight (kg):		-	-	20

HOL (m)	Length code	M1 (mm)	M2 (mm)	M3 (mm)	M4 (mm)	H3 (mm)	H4 (mm)	Weight (kg)
6	B	560	467	56	-37	49	157	200
9	C	560	567	56	63	73	57	210
12	D	780	667	176	63	97	57	220
15	E	780	787	56	63	127	57	230

This document is the absolute property of R&M Materials Handling, Inc. This document must not be copied without the written permission of R&M Materials Handling, Inc. The contents thereof must not be disclosed to a third party nor be used for any unauthorized purpose. Contravention will be prosecuted.

CSDPAL Design	CSDPAL Title	Appd	Ref Drawing	QB-F-04
2002-08-27 Date	HOIST: FIXED 4 ROPE FALLS			1 of 3 Title
SLEQEN01 Owner Dept	R&M MATERIALS HANDLING, INC. R&M & CONE DIVISIONS SHELDON, ILL.			DRAWN
	D002091-A			3