

FOOT MOUNT, 2 PART DOUBLE
Hoist type:
SX6 022...F0

SI-50Hz

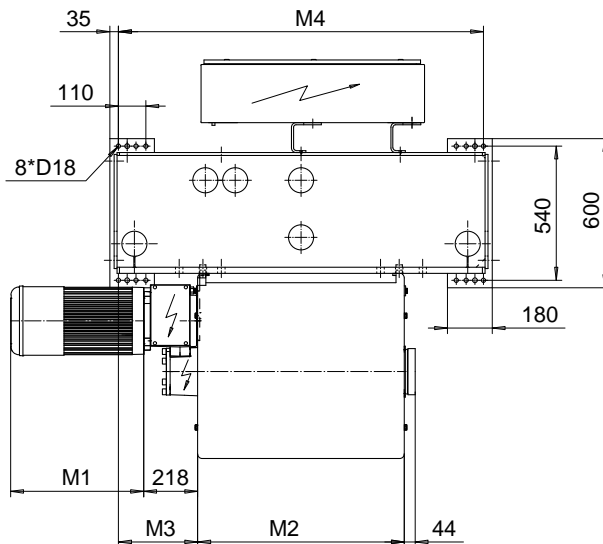
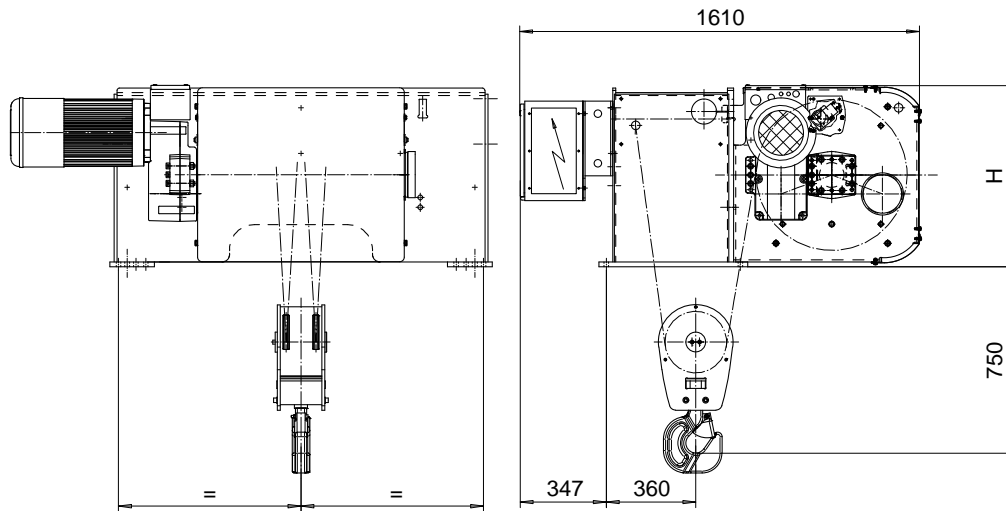

Motor	P6,T6,T7,T8,T9	P7,TA	P8
M1 (mm)	536	576	711

HOL (m)	Length code	M2 (mm)	M3 (mm)	M4 (mm)	H (mm)	Weight (kg)
16.5	E	682	394	1470	730	1400
22	F	832	319	1470	730	1450
29.5	G	1022	224	1470	730	1500
39	H	1272	599	2470	730	1825
52	J	1622	424	2470	730	1925
63.5	K	1922	274	2470	730	2025
77	L	2272	449	3170	830	2475
86.5	M	2522	324	3170	830	2575
98	N	2822	174	3170	830	2675

Load (kg)	Class Fem/ISO	Hoisting motor				
		Hoisting speed (m/min): Gear code				
		8/1.3 : E	10/1.7 : F	12.5/2 : G	16 : H	20 : J
6300	3m/M6	P6,T6	P6,T6	P7,T7	T8	T9
8000	2m/M5	P6,T6	P6,T6	P7,T7	T8	T9
10000	1Am/M4	P6,T6	P7,T7	P8,T8	T9	TA

ETFPAL	ETFPAL	Appd	Ref Drawing	QD-F-22
Design	2002-09-02	HOIST; FIXED		
Date		2x2 ROPE FALLS		
SLEQDOCV	Owner Dept	Folder		
R&M	R&M MATERIALS HANDLING, INC.	D002152-A		
	HOIST & CRANE PRODUCTS	Issue		
	SHREVEPORT, LOUISIANA	6		

This document is the absolute property of R&M Materials Handling, Inc. This document must not be copied without the written permission of R&M Materials Handling, Inc. The contents thereof must not be disclosed to a third party nor be used for any unauthorized purpose. Contravention will be prosecuted.