

FOOT MOUNT, 8 PART DOUBLE

Hoist type:

SX6 082...F0

SI-50Hz

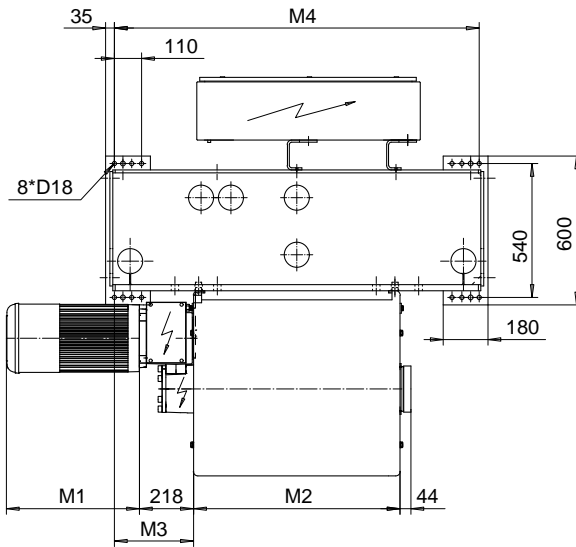
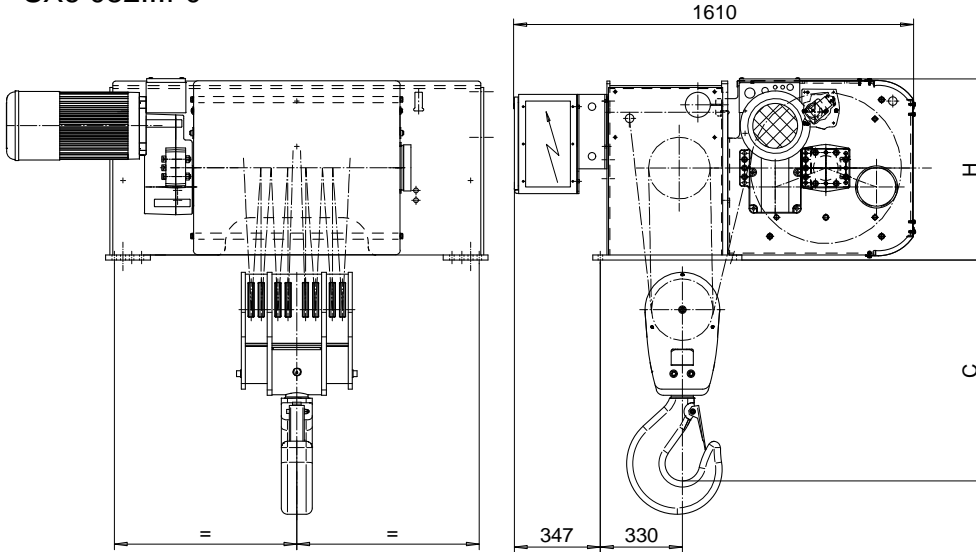

Motor	P6,T6,T7,T8,T9	P7,TA	P8
M1 (mm)	536	576	711

HOL (m)	Length code	M2 (mm)	M3 (mm)	M4 (mm)	H (mm)	C (mm)	Weight (kg)
5.5	F	832	319	1470	730	890	1650
7	G	1022	224	1470	730	890	1700
9.5	H	1272	559	2470	730	1050	2025
13	J	1622	424	2470	730	1050	2125
15.5	K	1922	274	2470	730	1050	2225
19	L	2272	449	3170	830	1050	2675
21.5	M	2522	324	3170	830	1050	2775
24.5	N	2822	174	3170	830	1050	2875

Load (kg)	Class Fem/ISO	Hoisting motor					
		Hoisting speed (m/min): Gear code					
		2/0.3: E	2.5/0.4: F	3.2/0.5: G	3.2: G	4: H	5: J
32000	2m/M5	P6,T6	P7,T7	----	T8	T9	TA
40000	1Am/M4	P6,T6	P7,T7	P8	T8	T9	TA

ETTPAL Design	KHHMKH Chd	Appd	Ref Drawing	QD-F-28
2002-09-03 Date	HOIST; FIXED			
SLEQDOCV Owner Dept	2x8 ROPE FALLS			
R&M R&M MATERIALS HANDLING, INC. BUCKLE & CHAIN PRODUCTS SPRINGFIELD, OHIO	D002159-A			Issue 7

This document is the absolute property of R&M Materials Handling, Inc. This document must not be copied without the written permission of R&M Materials Handling, Inc. The contents thereof must not be disclosed to a third party nor be used for any unauthorized purpose. Contravention will be prosecuted.