

FOOT MOUNT, 6 PART DOUBLE
Hoist type:
SX7 062...F0

SI-60Hz

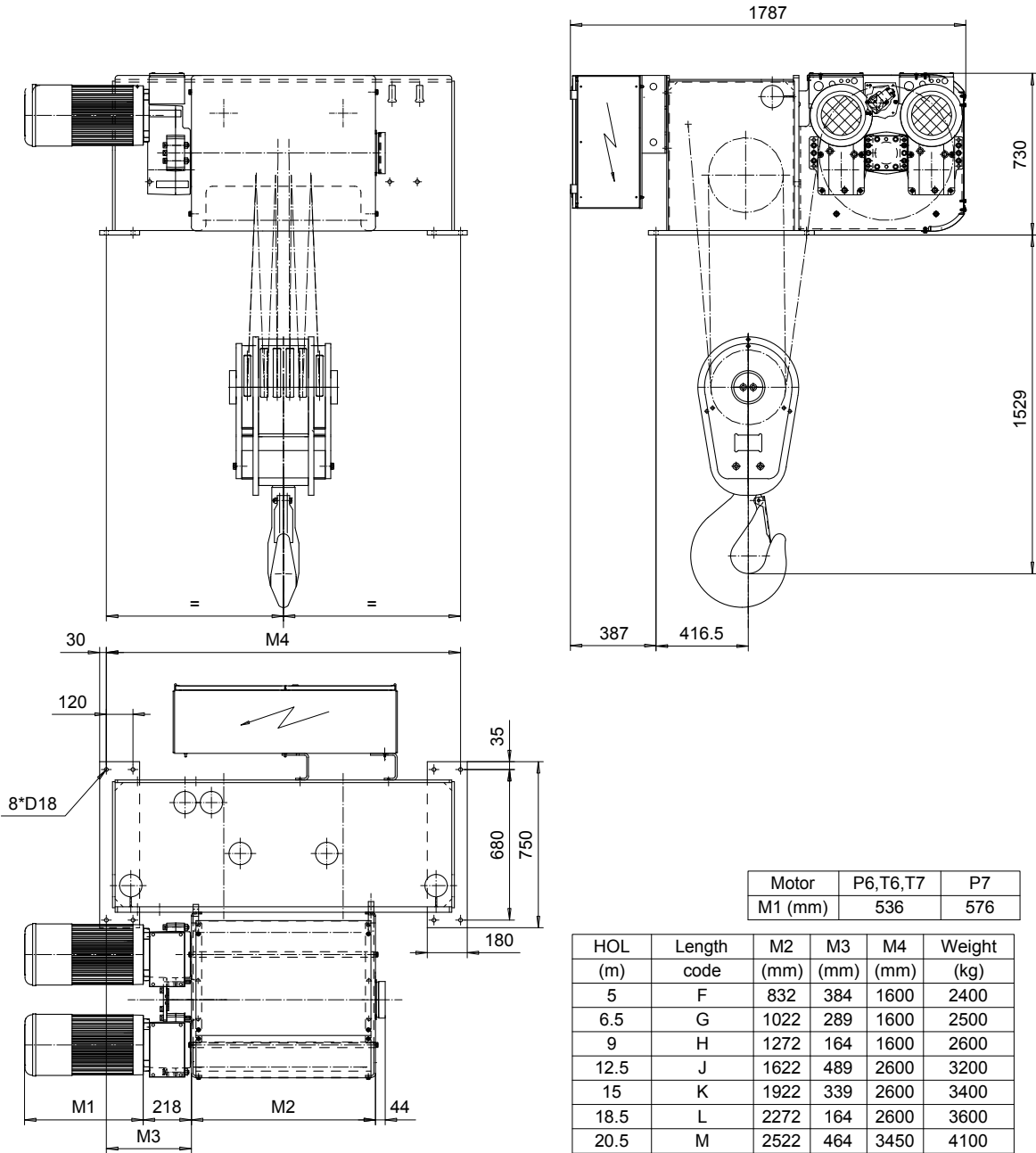

Motor	P6,T6,T7	P7
M1 (mm)	536	576

HOL (m)	Length code	M2 (mm)	M3 (mm)	M4 (mm)	Weight (kg)
5	F	832	384	1600	2400
6.5	G	1022	289	1600	2500
9	H	1272	164	1600	2600
12.5	J	1622	489	2600	3200
15	K	1922	339	2600	3400
18.5	L	2272	164	2600	3600
20.5	M	2522	464	3450	4100
23.5	N	2822	314	3450	4300

Load (kg)	Class Fem/ISO	Hoisting motor				
		Hoisting speed (m/min): Gear code				
		3/0.5: E	3.8/0.6: F	4.8/0.7: G	6: H	7.5: J
40000	3m/M6	P6,T6	P6,T6	P7,T7	T8	T9
50000	2m/M5	P6,T6	P6,T6	P7,T7	T8	T9
60000	1Am/M4	P6,T6	P7,T7	T8	T9	-

This document is the absolute property of R&M Materials Handling, Inc. This document must not be copied without the written permission of R&M Materials Handling, Inc. The contents thereof must not be disclosed to a third party nor be used for any unauthorized purpose. Contravention will be prosecuted.

ETFPAL Design 2003-01-13 Date	ETFPAL Chd Appd	Ref Drawing	QE-F-26
SLEQDOCV Owner Dept	HOIST; FIXED 2X6 ROPE FALLS		1 of 13 Folder
R&M MATERIALS HANDLING, INC. HOIST & CRANE PRODUCTS SERRAVALLO, OHIO	D002335-A		Issue 6