

**NORMAL HEADROOM, 4 PART SINGLE**  
**Hoist type:**  
**SX4 041...N0**

SI-50Hz

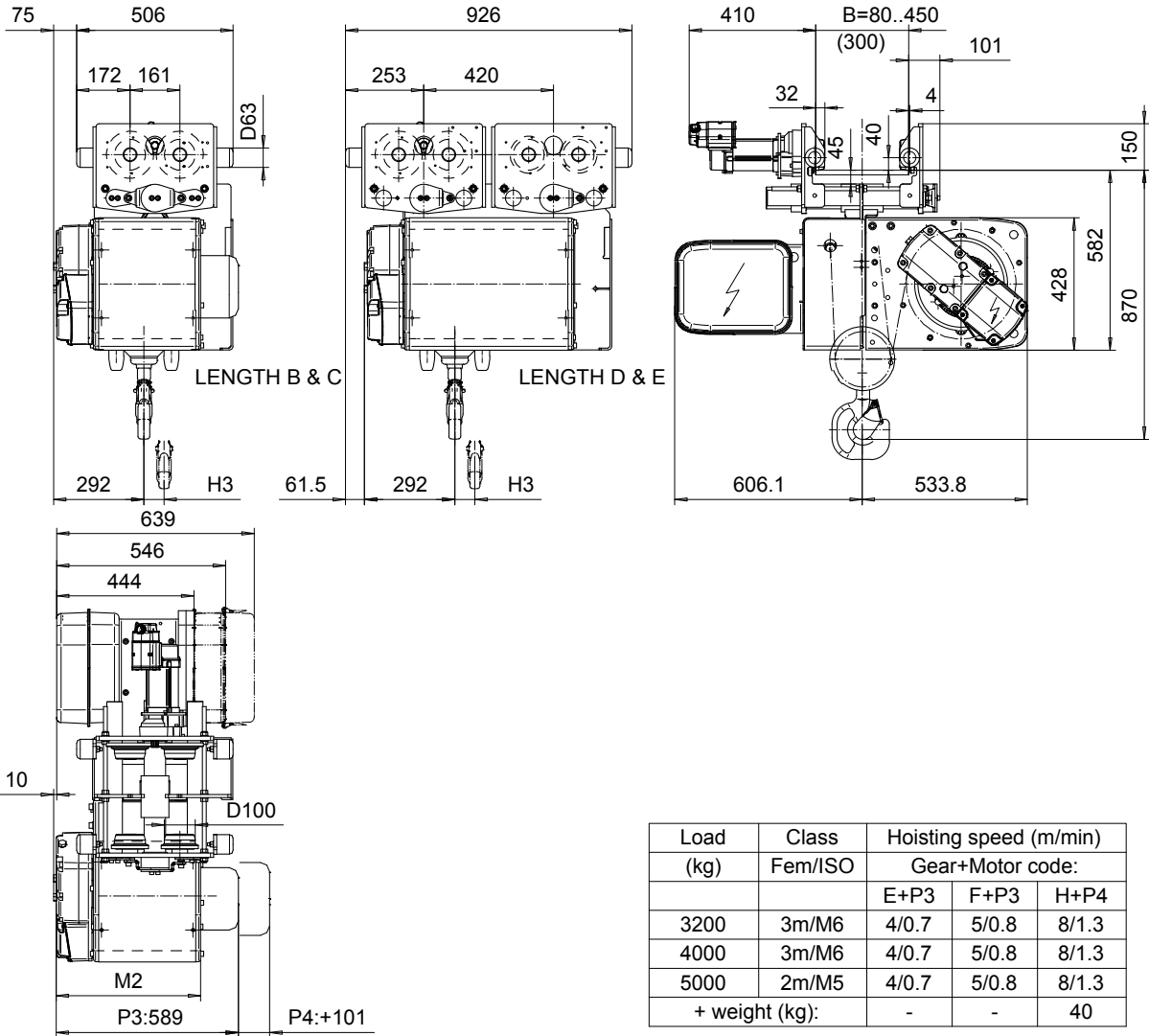

Load (kg)	Class Fem/ISO	Hoisting speed (m/min)		
		Gear+Motor code:		
		E+P3	F+P3	H+P4
3200	3m/M6	4/0.7	5/0.8	8/1.3
4000	3m/M6	4/0.7	5/0.8	8/1.3
5000	2m/M5	4/0.7	5/0.8	8/1.3
+ weight (kg):		-	-	40

HOL (m)	Length code	M2 (mm)	H3 (mm)	Weight (kg)
6	B	467	49	355
9	C	567	73	380
12	D	667	97	415
15	E	787	121	435

This document is the absolute property of R&M Materials Handling, Inc. This document must not be copied without the written permission of R&M Materials Handling, Inc. The contents thereof must not be disclosed to a third party nor be used for any unauthorized purpose. Contravention will be prosecuted.

ETFPAL Design	ETFPAL Chd	Appd	Ref Drawing	QB-N-04
2002-08-28 Date	TROLLEY; NORMAL HEADROOM			1:10 Folder
SLEQDCV Owner Dept	4 ROPE FALLS			
R&M MATERIALS HANDLING, INC. HOIST & CRANE PRODUCTS	D002097-A			Issue 3