

NORMAL HEADROOM, 6 PART SINGLE

Hoist type:

SX4 061...N0

SI-50Hz

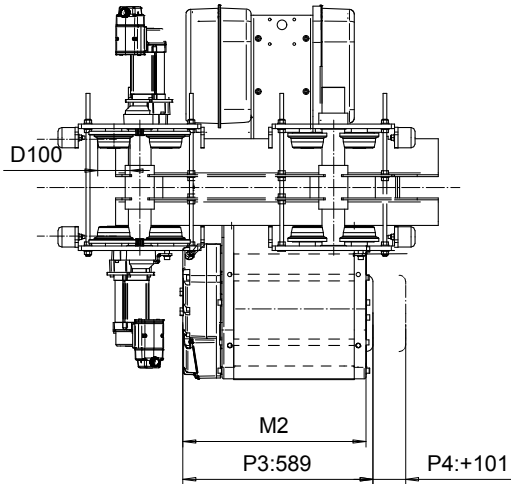
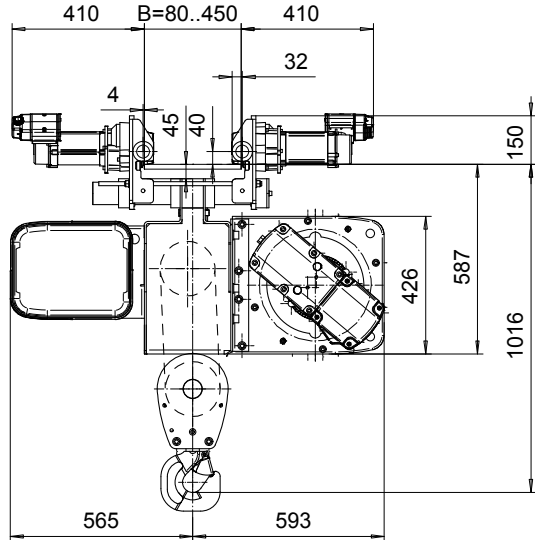
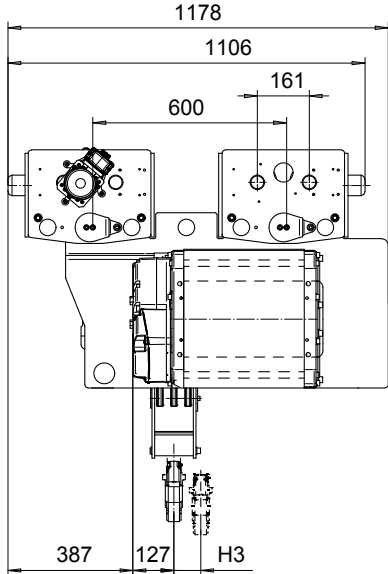

Load (kg)	Class Fem/ISO	Hoisting speed (m/min)	
		Gear+Motor code:	
		F+P3	H+P4
6000	3m/M6	3.2/0.5	5/0.8
7500	2m/M5	3.2/0.5	5/0.8
+ weight (kg):		-	40

HOL (m)	Length code	M2 (mm)	H3 (mm)	Weight (kg)
6	C	567	49	540
8	D	667	65	560
10	E	787	85	585

This document is the absolute property of R&M Materials Handling, Inc. This document must not be copied without the written permission of R&M Materials Handling, Inc. The contents thereof must not be disclosed to a third party nor be used for any unauthorized purpose. Contravention will be prosecuted.

ETFPAL Design	ETFPAL Chd	Appd	Ref Drawing	QB-N-06
2002-08-28 Date	TROLLEY; NORMAL HEADROOM			 1:10 Folded
SLEQDCV Owner Dept	6 ROPE FALLS			
R&M MATERIALS HANDLING, INC. HOIST & CRANE PRODUCTS SHEPPARD AVENUE ANN ARBOR, MI 48106	D002100-A			Issue 3