

NORMAL HEADROOM, 8 PART SINGLE
Hoist type:
SX4 081...N0

SI-50Hz

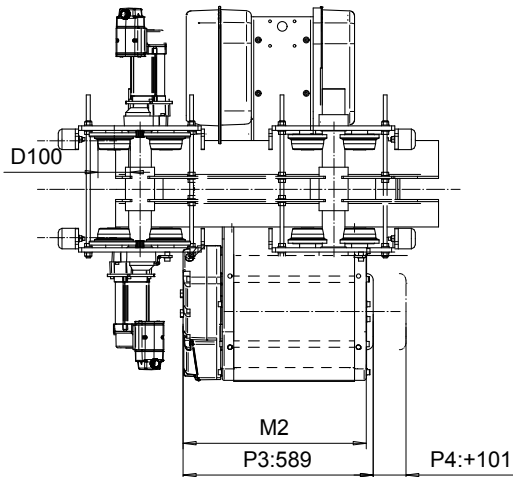
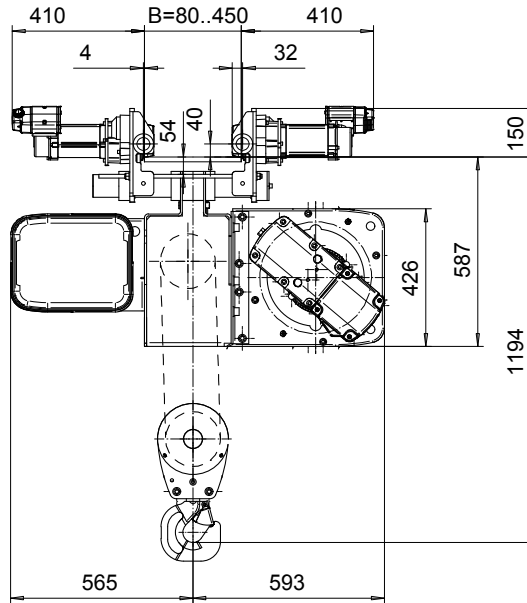
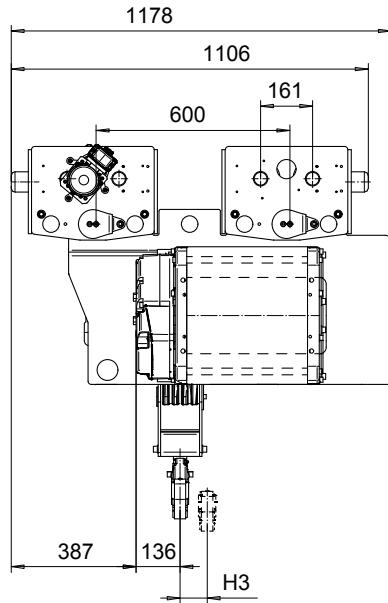

Load (kg)	Class Fem/ISO	Hoisting speed (m/min)	
		Gear+Motor code:	
		F+P3	H+P4
8000	2m/M5	2.5/0.4	4/0.7
10000	1Am/M4	2.5/0.4	4/0.7
+ weight (kg):		-	40

HOL	Length (m)	M2 code	M2 (mm)	H3 (mm)	Weight (kg)
4.5	C	567	37	545	
6	D	667	49	565	
7.5	E	787	64	590	

This document is the absolute property of R&M Materials Handling, Inc. This document must not be copied without the written permission of R&M Materials Handling, Inc. The contents thereof must not be disclosed to a third party nor be used for any unauthorized purpose. Contravention will be prosecuted.

ETFPAL Design	ETFPAL Chd	Appd	Ref Drawing	QB-N-08
2002-08-28 Date	TROLLEY; NORMAL HEADROOM			3 of 3 Folder
SLEQDCV Owner Dept	8 ROPE FALLS			
R&M MATERIALS HANDLING, INC. HOIST & CRANE PRODUCTS	D002104-A			Issue 3