

NORMAL HEADROOM, 4 PART SINGLE
Hoist type:
SX5 041...N0

SI-50Hz

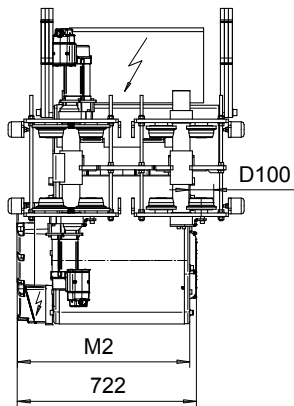
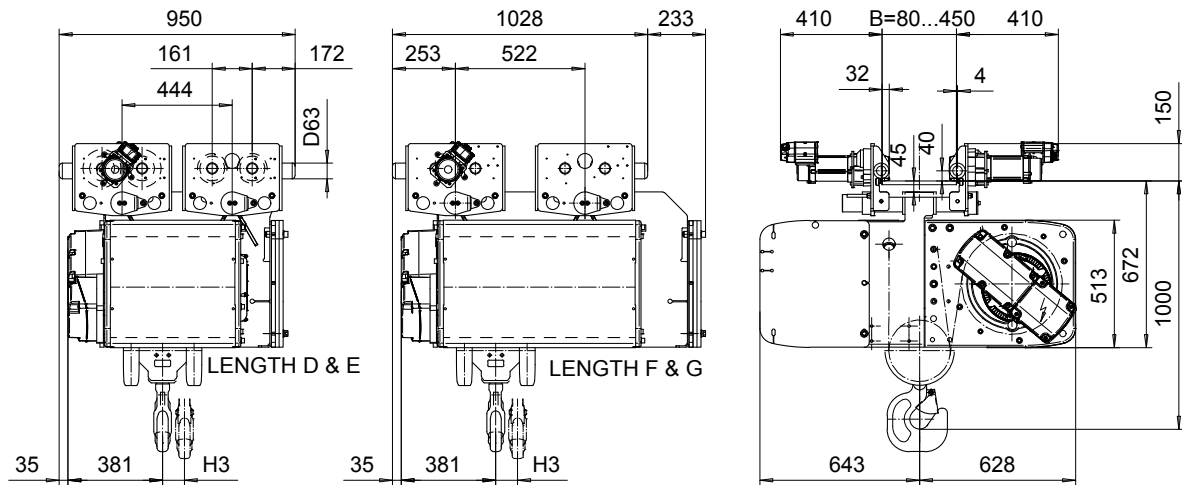

Load (kg)	Class Fem/ISO	Hoisting speed (m/min)			
		Gear+Motor code:			
		E+P5	F+P5	H+P6	J+P7
6300	3m/M6	4/0.7	5/0.8	8/1.3	10/1.7
8000	3m/M6	4/0.7	5/0.8	8/1.3	10/1.7
10000	2m/M5	4/0.7	5/0.8	8/1.3	10/1.7
+ weight (kg):		-	-	60	80

HOL (m)	Length code	M2 (mm)	H3 (mm)	Weight (kg)
9	D	697	88	570
12	E	817	118	620
16	F	967	156	660
20	G	1157	204	700

This document is the absolute property of R&M Materials Handling, Inc. This document must not be copied without the written permission of R&M Materials Handling, Inc. The contents thereof must not be disclosed to a third party nor be used for any unauthorized purpose. Contravention will be prosecuted.

ETFPAL Design	ETFPAL Chd	Appd	Ref Drawing	QC-N-04
2002-08-30 Date	TROLLEY; NORMAL HEADROOM			1 of 15 Folder
SLEQDCV Owner Dept	4 ROPE FALLS			
R&M MATERIALS HANDLING, INC. HOIST & CRANE PRODUCTS SHERBOURNE, ONT.	D002120-A			Issue 3