

SI-50Hz

NORMAL HEADROOM, 4 PART SINGLE
Hoist type:
SX6 041...N0

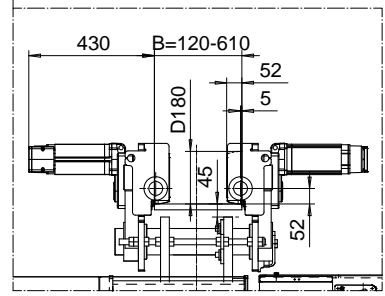

OPTION: CURVED TRACK SUSPENSION

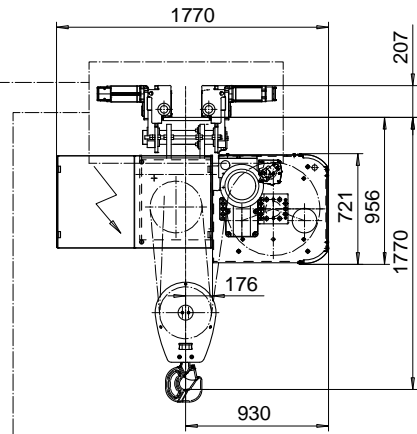
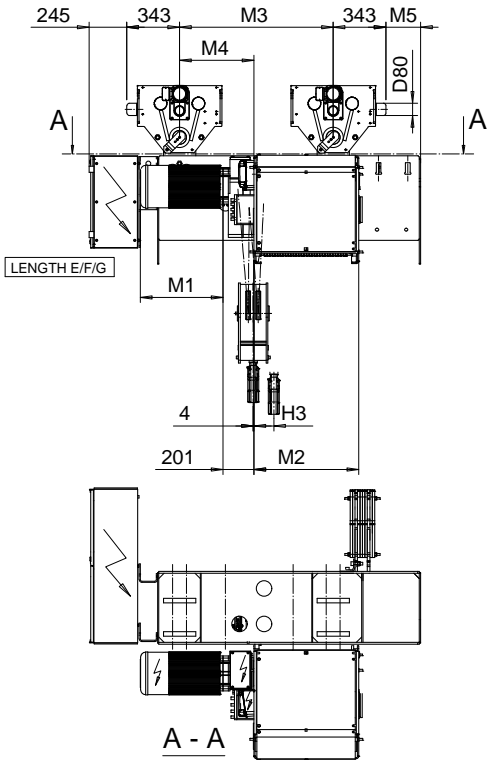
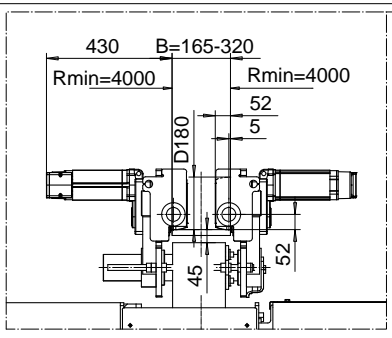

Motor	P6,T6,T7,T8,T9	P7,TA	P8
M1 (mm)	536	576	711

HOL (m)	Length code	M2 (mm)	M3 (mm)	M4 (mm)	M5 (mm)	H3 (mm)	Weight (kg)
7.5	C	462	1200	484	-200	69	1900
10.5	D	562	1200	484	-200	94	1925
14	E	682	1000	484	225	125	2025
18	F	832	1000	484	225	161	2125
23.5	G	1022	1000	484	225	210	2275
30.5	H	1272	1450	574	765	273	2575
40	J	1622	1450	574	765	360	2875
48.5	K	1922	1450	574	765	434	3075

Note: Weight when B = 12"

Load (kg)	Class Fem/ISO	Hoisting motor				
		Hoisting speed (m/min): Gear code				
		4/0.7: E	5/0.8: F	6.3/1.1: G	8: H	10: J
12500	3m/M6	P6,T6	P6,T6	P7,T7	T8	T9
16000	2m/M5	P6,T6	P6,T6	P7,T7	T8	T9
20000	1Am/M4	P6,T6	P7,T7	P8,T8	T9	TA

This document is the absolute property of R&M Materials Handling, Inc. This document must not be copied without the written permission of R&M Materials Handling, Inc. The contents thereof must not be disclosed to a third party nor be used for any unauthorized purpose. Contravention will be prosecuted.

ETVPH Design	ETTPAL Clus	Appd	Ref Drawing	QD-N-04
2003-09-04 Date	TROLLEY; NORMAL HEADROOM			
SLEQDOCV Owner Dept	4 ROPE FALLS			
R&M MATERIALS HANDLING, INC. SERIES 4 ROPE PRODUCTS SUSPENDED, STD	D002694-A			
				2