

NORMAL HEADROOM, 6 PART DOUBLE
Hoist type:
SX6 062...N0

SI-50Hz

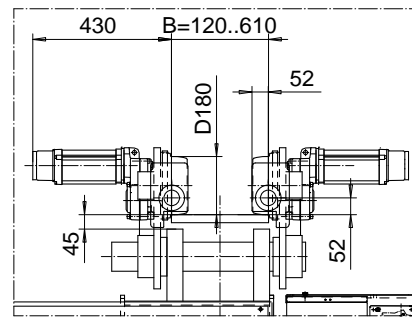

OPTION: CURVED TRACK SUSPENSION

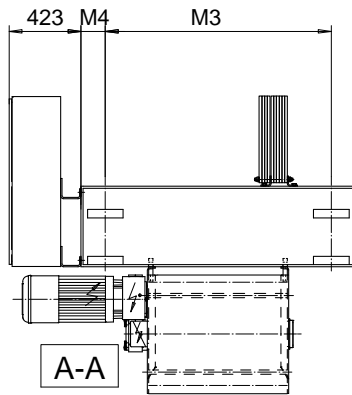
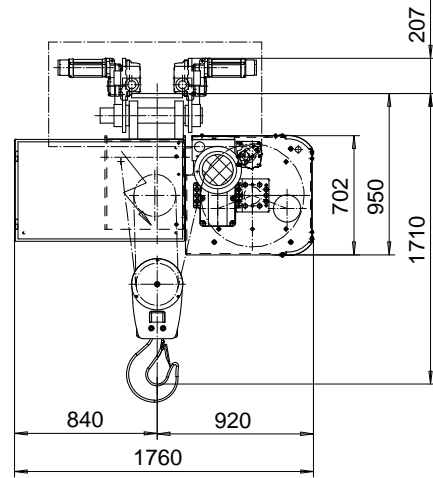
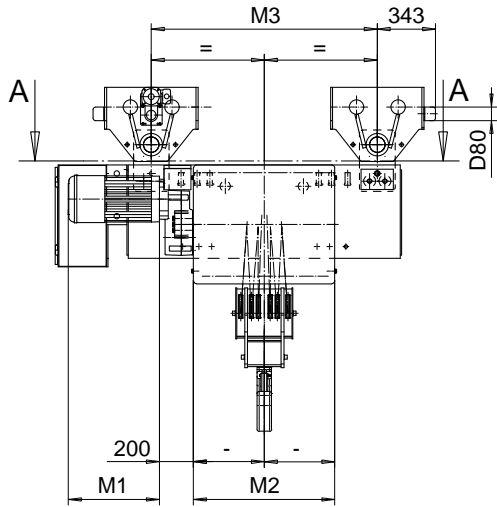
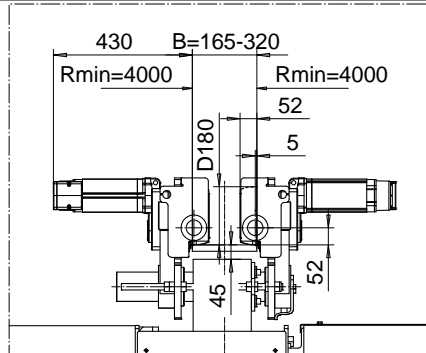

Motor	P6,T6,T7,T8,T9	P7,TA	P8
M1 (mm)	536	576	711

HOL (m)	Length code	M2 (mm)	M3 (mm)	M4 (mm)	Weight (kg)
5.5	E	682	1330	145	1850
7	F	832	1330	145	1950
9.5	G	1022	1330	145	2050
13	H	1272	1930	145	2250
17	J	1622	1930	145	2500
21	K	1922	1330	530	2700
25.5	L	2272	1330	530	3050
28.5	M	2522	1330	805	3250
32.5	N	2822	1330	805	3500

Note: Weight when B = 300mm

Load (kg)	Class Fem/ISO	Hoisting motor				
		Hoisting speed (m/min): Gear code				
		2.5/0.4: E	3.2/0.5: F	4/0.7: G	5: H	6.3: J
20000	3m/M6	P6,T6	P6,T6	P7,T7	T8	T9
25000	2m/M5	P6,T6	P6,T6	P7,T7	T8	T9
30000	1Am/M4	P6,T6	P7,T7	P8,T8	T9	TA

This document is the absolute property of R&M Materials Handling, Inc. This document must not be copied without the written permission of R&M Materials Handling, Inc. The contents thereof must not be disclosed to a third party nor be used for any unauthorized purpose. Contravention will be prosecuted.

CSDTLI Design 2003-04-15 Date	KHHMKH Chd	Appd	Ref Drawing	QD-N-26
SLEQDOCV Owner Dept	TROLLEY; NORMAL HEADROOM 2x6 ROPE FALLS			1 of 19 Folder
R&M R&M MATERIALS HANDLING, INC. HOIST & CRANE PRODUCTS SARASOTA, FL 34237	D002536-A			Issue 3