

SPECIAL LOW HEADROOM, 4 PART SINGLE

Hoist type:

SX1 041...J0

SI-60Hz

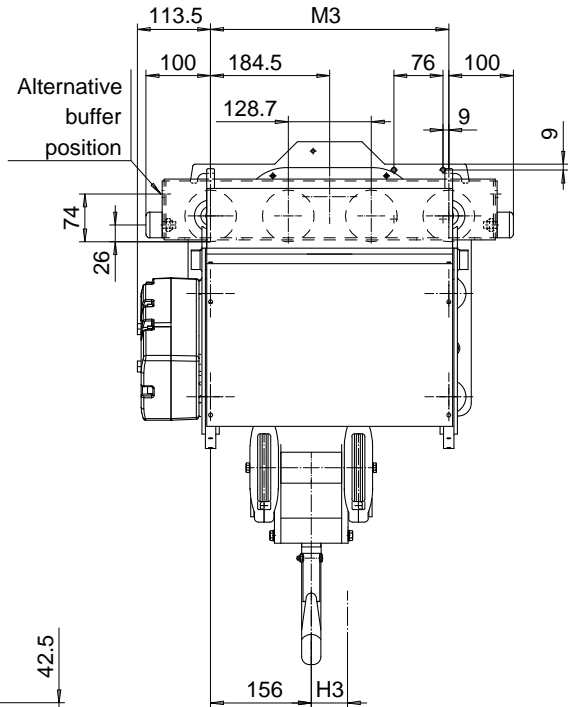
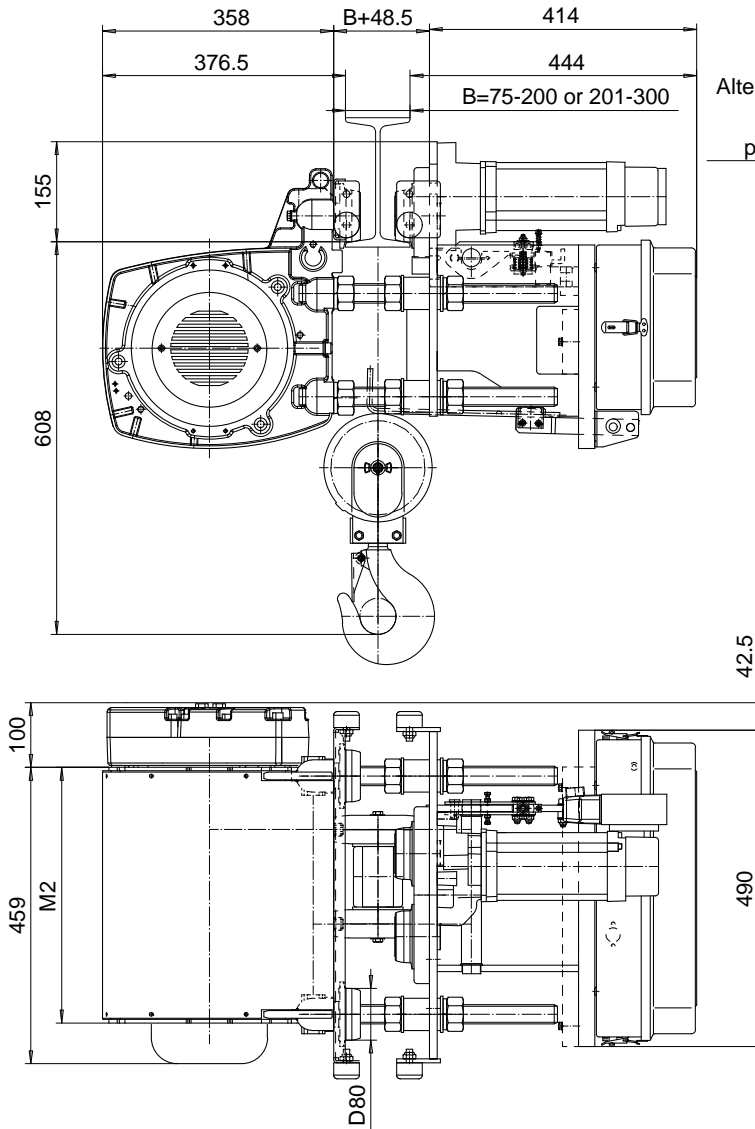

Load (kg)	Class FEM / ISO	Hoisting speed (m/m) Gear+Motor code:
		E+PX
2000	2m / M5	4.8/ 0.8

HOL [m]	Length code	M2 [mm]	M3 [mm]	H3 [mm]	Weight [kg]
6	B	396	369	56	190
9	C	506	479	84	215

This document is the absolute property of R&M Materials Handling, Inc. This document must not be copied without the written permission of R&M Materials Handling, Inc. The contents thereof must not be disclosed to a third party nor be used for any unauthorized purpose. Contravention will be prosecuted.

KHHMHE	Chd	Appd	Ref Drawing	QZ-J-04
Design 2004-11-05	HOIST; SPECIAL LOW HEADROOM			3/5 Folder
Date SLEQDOCV	4 ROPE FALLS			
Owner Dept	D003696-A			Issue 5