

LOW HEADROOM, 2 PART SINGLE

Hoist type:

SX5 021...L0

SI-60Hz

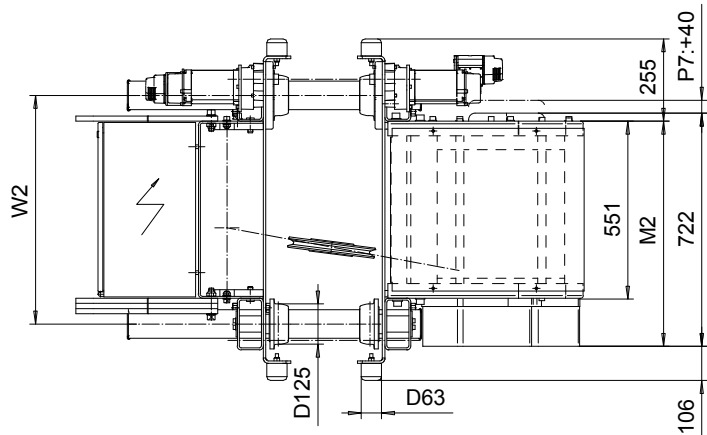
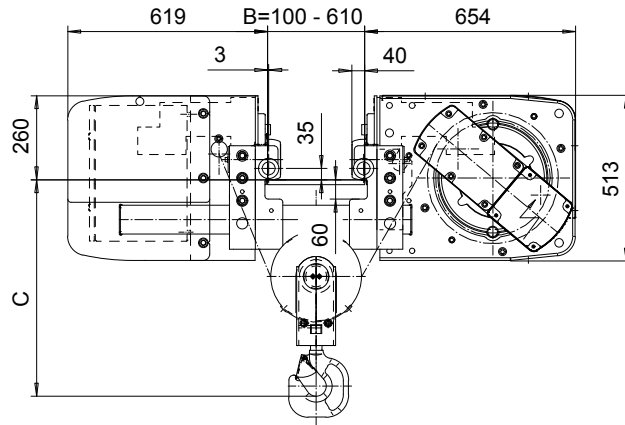
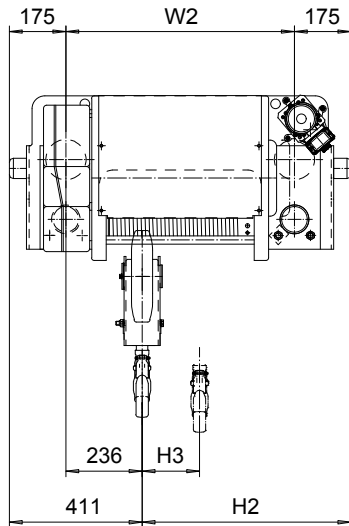

HEADROOM TABLE	
Flange Width, B (mm)	Headroom, C (mm)
100 - 199	630
200 - 259	600
260 - 440	580
341 - 540	640
551 - 610	680

Headroom is related to the flange width

Load (kg)	Class Fem/ISO	Hoisting speed (m/min)			
		Gear+Motor code:			
		E+P5	F+P5	H+P6	J+P7
4000	3m/M6	9.5/1.6	12/2	19/3.2	24/4
5000	2m/M5	9.5/1.6	12/2	19/3.2	24/4
+ weight (kg):		-	-	60	80

HOL (m)	Length code	M2 (mm)	H2 (mm)	H3 (mm)	W2 (mm)	Weight (kg)
18	D	697	647	176	708	680
24	E	817	767	235	828	725
32	F	967	917	309	978	962

This document is the absolute property of R&M Materials Handling, Inc. This document must not be copied without the written permission of R&M Materials Handling, Inc. The contents thereof must not be disclosed to a third party nor be used for any unauthorized purpose. Contravention will be prosecuted.

ETFPAL Design	ETFPAL Chd	Appd	Ref Drawing	QC-L-02
2002-08-29 Date	TROLLEY; LOW HEADROOM			2:1:0 Folder
SLEQRON Owner Dept	2 ROPE FALLS			
R&M MATERIALS HANDLING, INC. HOIST & CRANE PRODUCTS	D002112-A			Issue 4