

NORMAL HEADROOM, 8 PART DOUBLE
Hoist type:
SX5082...N0

SI-60Hz

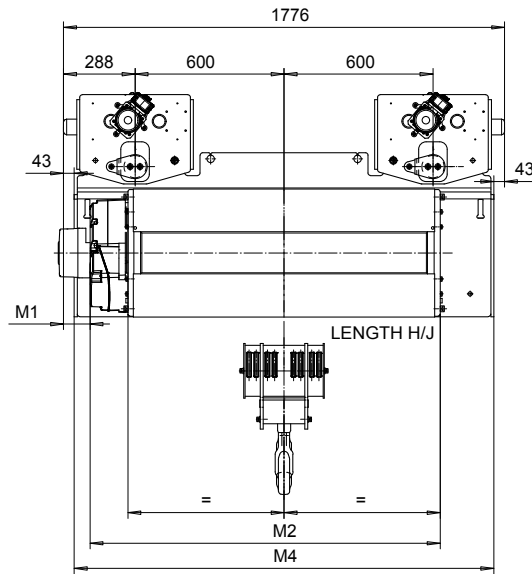
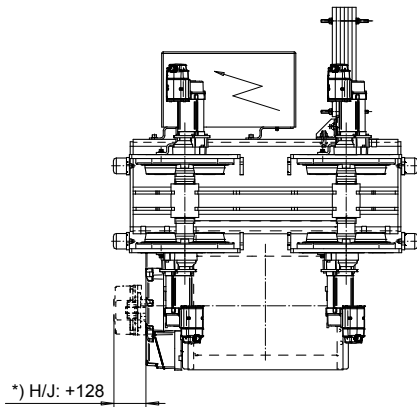
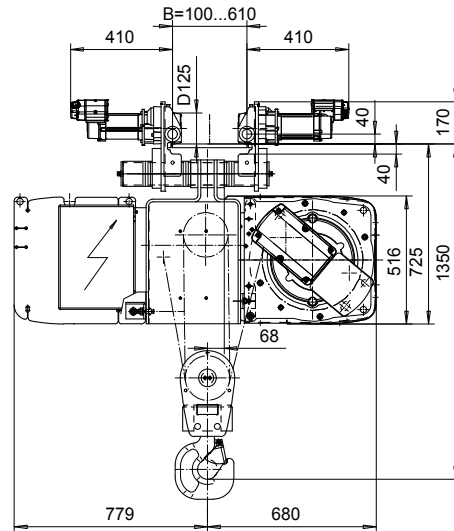
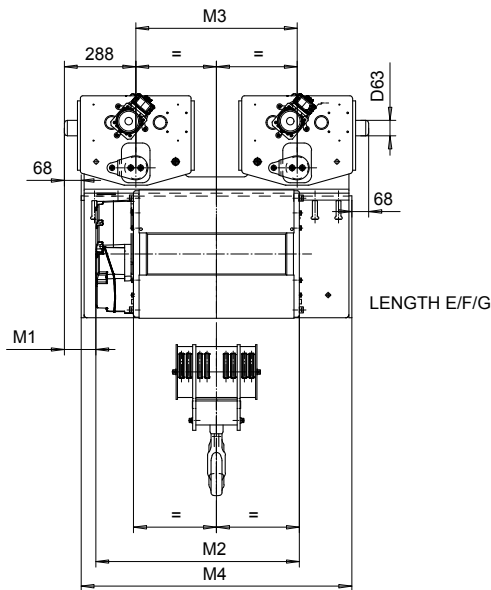

Load (kg)	Class Fem/ISO	Hoisting speed (m/min)		
		Gear+Motor code:		
		F+P5	H+P6	J+P7
16000	2m/M5	3/0.5	4.8/0.8	6/1
20000	1Am/M4	3/0.5	4.8/0.8	6/1
+ weight (kg):		-	60	80

HOL (m)	Length code	M1 (mm)	M2 (mm)	M3 (mm)	M4 (mm)	Weight (kg)
4.5	F	52	967	650	1090	1150
6	G	- 43	1157	650	1090	1190
8	H	107	1407	1200	1690	1400
11.5	J	- 68	1757	1200	1690	1490

Note:
 Weight calculated, when B=300mm

Note:
 *) Gear brake as standard brake for drum lengths H and J

This document is the absolute property of R&M Materials Handling, Inc. This document must not be copied without the written permission of R&M Materials Handling, Inc. The contents thereof must not be disclosed to a third party nor be used for any unauthorized purpose. Contravention will be prosecuted.

ETVPH Design	ETVPH Chd	Appd	Ref Drawing	QC-N-28
2004-04-27 Date	TROLLEY; NORMAL HEADROOM			1 of 15 Folder
SLEQDCV Owner Dept	2x8 ROPE FALLS			
R&M MATERIALS HANDLING, INC. HOIST & CRANE PRODUCTS	D003137-A			Issue 3