

TROLLEY; NORMAL HEADROOM, 6 PART SINGLE

Hoist type:

SX5 061...N0

US-60Hz

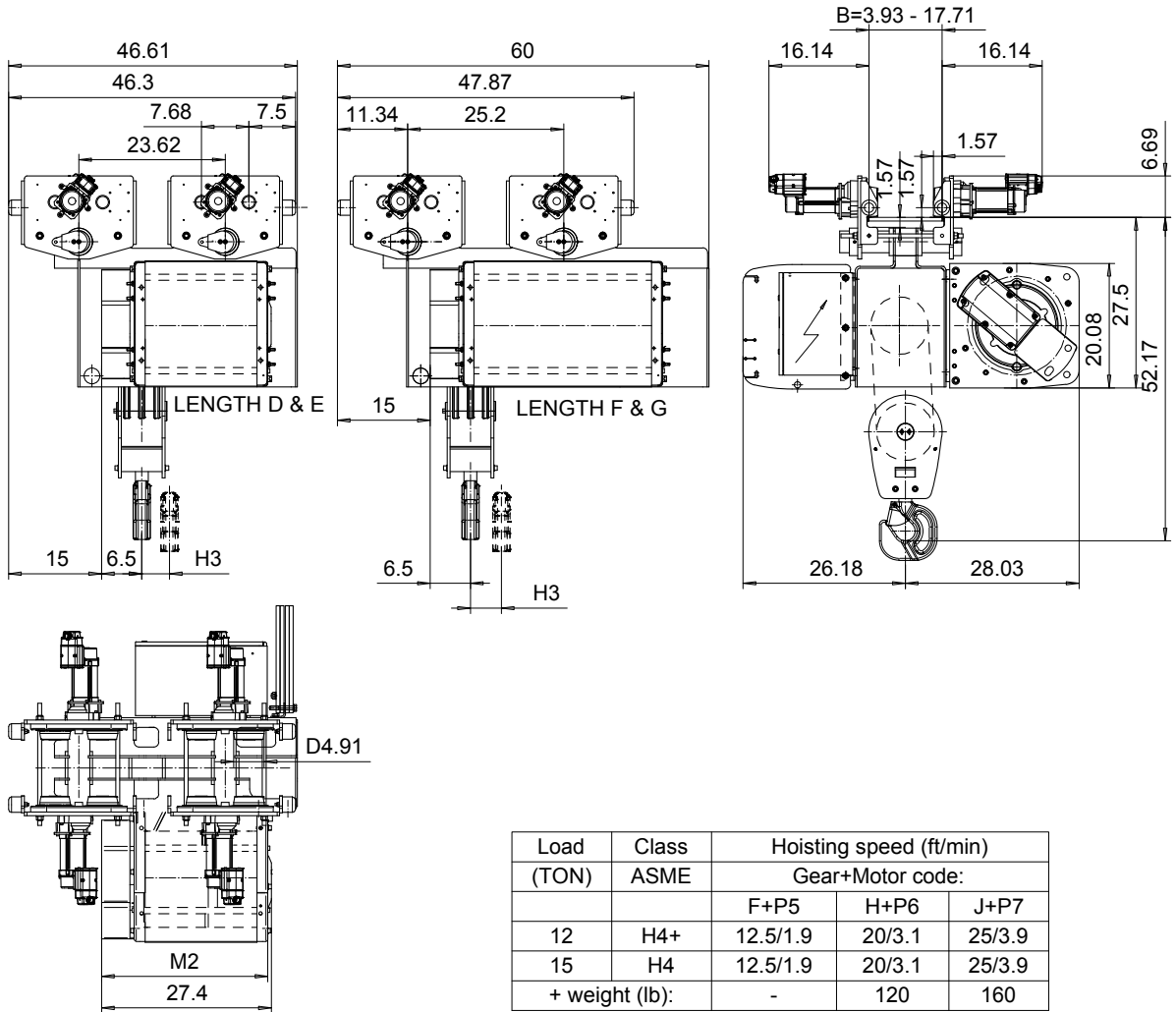

This document is the absolute property of R&M Materials Handling, Inc. This document must not be copied without the written permission of R&M Materials Handling, Inc. The contents thereof must not be disclosed to a third party nor be used for any unauthorized purpose. Contravention will be prosecuted.

ETFPAL Design	ETFPAL Chd	Appd	Ref Drawing	QC-N-06
2002-08-30 Date	TROLLEY; NORMAL HEADROOM			1 of 15 Folder
SLEQDCV Owner Dept	6 ROPE FALLS			
R&M MATERIALS HANDLING, INC. HOIST & CRANE PRODUCTS	D002125-A			Issue 3