

# NORMAL HEADROOM, CURVED TRACK; 4 PART SINGLE

Hoist type:

SX4 041...N0

SI-50Hz

Lengths B/C

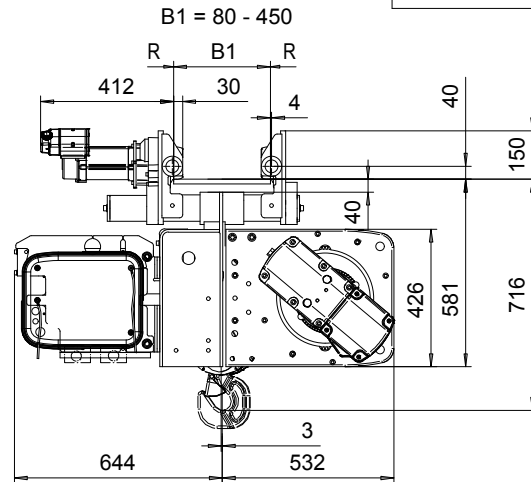
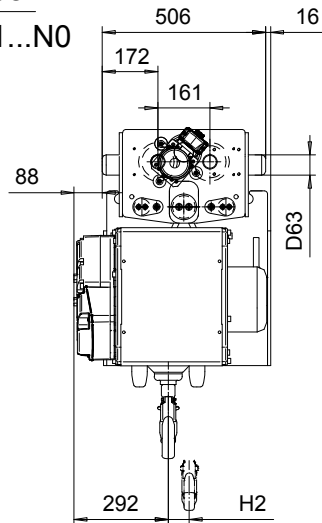

Lengths D/E

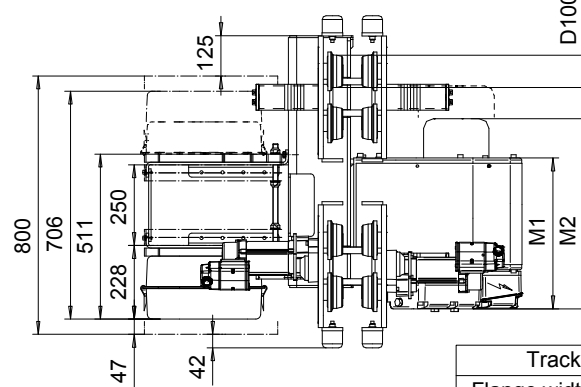
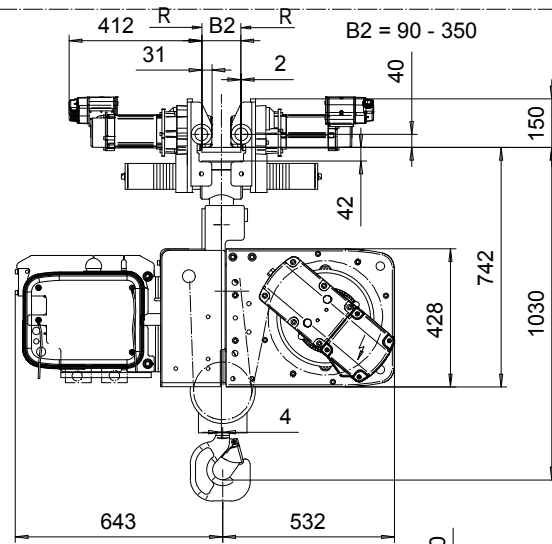
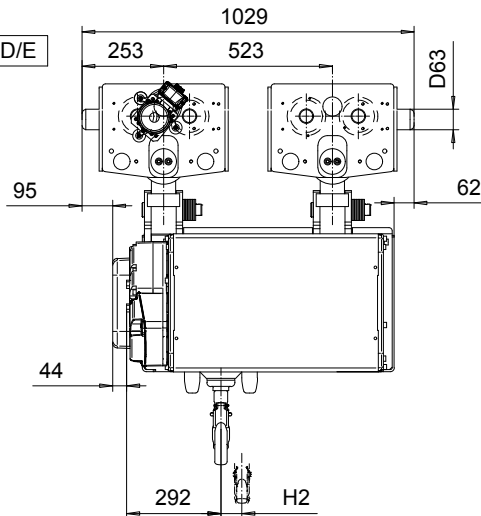

Motor Dimensions				
Motor	P3	P4	T3	T4
M2 (mm)	597	690	507	610
Weight (kg)	35	53	22	45

Hoist Dimensions				
HOL	Length	M1	H2	Weight
(m)	code	(mm)	(mm)	(kg)
6	B	467	49	400
9	C	567	73	430
12	D	667	97	440
15	E	787	121	550

Note: Weight calculated, when B=300mm

Load (kg)	Class Fem/ISO	Hoisting speed (m/min)		
		E+P3	F+P3	H+P4
Gear+Motor code:				
3200	3m/M6	4/0.7	5/0.8	8/1.3
4000	3m/M6	4/0.7	5/0.8	8/1.3
5000	2m/M5	4/0.7	5/0.8	8/1.3

Track Radius	
Flange width B	R min
80 - 109	2500
110 - 119	2000
120 - 450	1500

Total weight = Hoist weight + Motor weight

This document is the absolute property of R&M Materials Handling, Inc. This document must not be copied without the written permission of R&M Materials Handling, Inc. The contents thereof must not be disclosed to a third party nor be used for any unauthorized purpose. Contravention will be prosecuted.

ETTVPH Design	ETTVPH Chd	Appd	Ref Drawing	QB-N-04
2004-12-23 Date	TROLLEY; NORMAL HEADROOM CURVED TRACK; 4 ROPE FALLS			3 of 3 Folder
SLEODOCV Owner Dept	R&M MATERIALS HANDLING, INC. HOIST & CRANE PRODUCTS SPRINGFIELD, OHIO			Issue 2
D003841-A				