

NORMAL HEADROOM, CURVED TRACK, 4 PART SINGLE

Hoist type:

SX5 041...N0

SI-50Hz

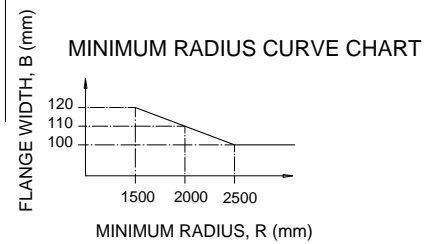
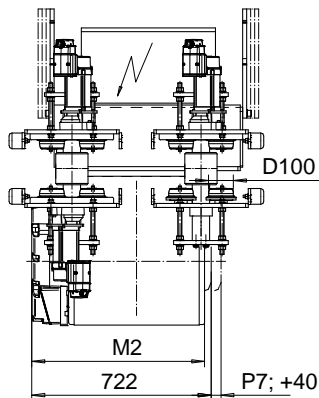
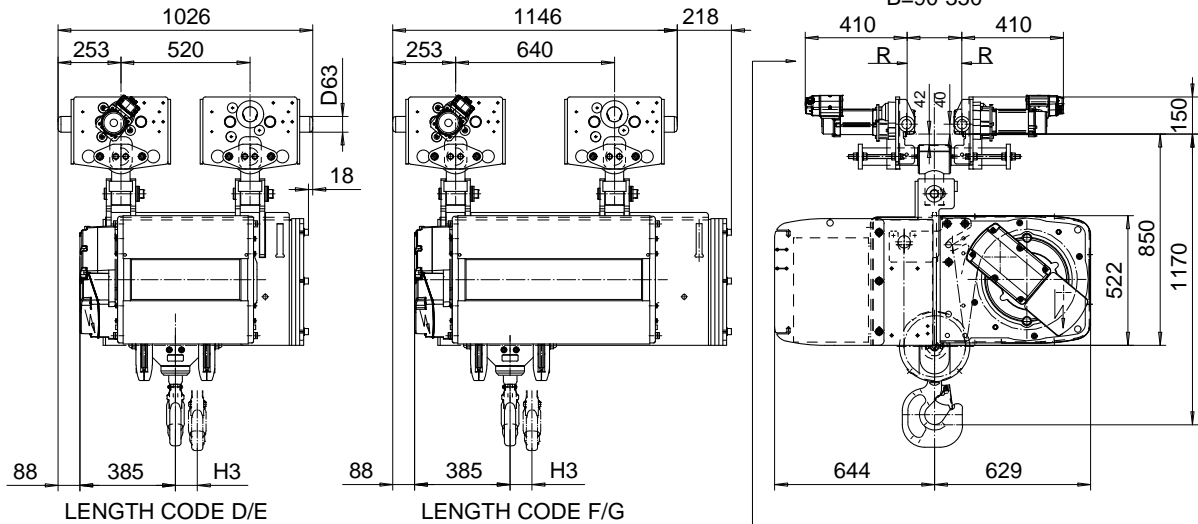

Load (kg)	Class Fem/ISO	Hoisting speed (m/min)			
		Gear+Motor code:			
		E+P5	F+P5	H+P6	J+P7
6300	3m/M6	4/0.7	5/0.8	8/1.3	10/1.7
8000	3m/M6	4/0.7	5/0.8	8/1.3	10/1.7
10000	2m/M5	4/0.7	5/0.8	8/1.3	10/1.7
+ weight (kg):		-	-	60	80

HOL (m)	Length code	M2 (mm)	H3 (mm)	Weight (kg)
9	D	697	88	890
12	E	817	118	960
16	F	967	156	1000
20	G	1157	204	1100

ETVPH Design	ETVPH Chd	Appd	Ref Drawing	QC-N-04
2005-06-20 Date	TROLLEY; NORMAL HEADROOM			1 of 13 Folder
SLEQDOCV Owner Dept	CURVED TRACK, 4 ROPE FALLS			
R&M R&M MATERIALS HANDLING, INC. HOIST & CRANE PRODUCTS SARASOTA, FL 34237	D004136-A			Issue 1

This document is the absolute property of R&M Materials Handling, Inc. This document must not be copied without the written permission of R&M Materials Handling, Inc. The contents thereof must not be disclosed to a third party nor be used for any unauthorized purpose. Contravention will be prosecuted.