

NORMAL HEADROOM, CURVED TRACK, 8 PART SINGLE

Hoist type:

SI-60Hz

SX5 081...N0

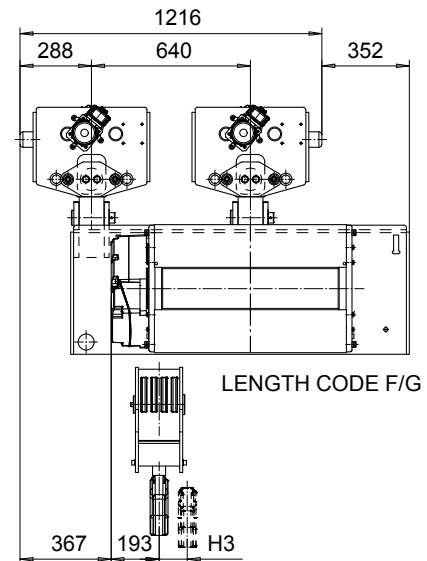
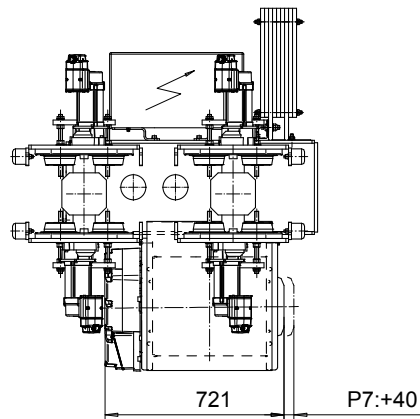
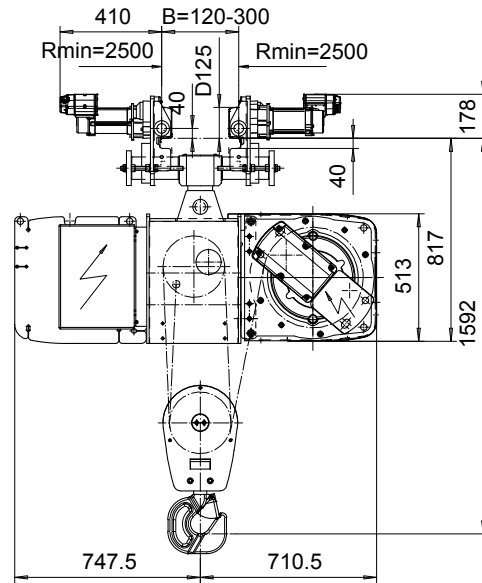
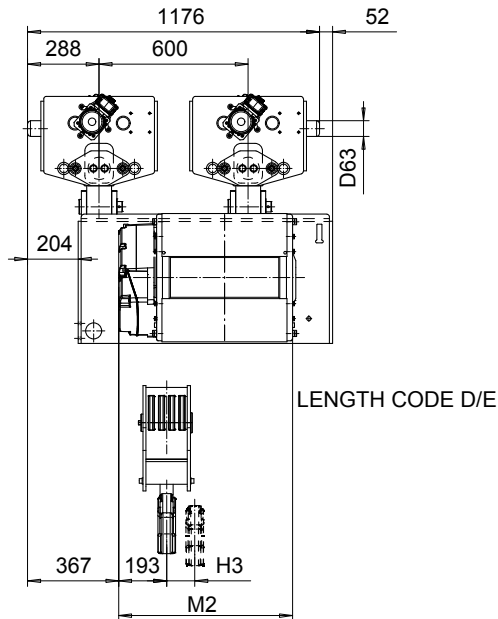

Load (kg)	Class Fem/ISO	Hoisting speed (m/min)		
		Gear+Motor code:		
		F+P5	H+P6	J+P7
16000	2m/M5	3/0.5	4.8/0.8	6/1
20000	1Am/M4	3/0.5	4.8/0.8	6/1
+ weight (kg):		-	60	80

HOL (m)	Length code	M2 (mm)	H3 (mm)	Weight (kg)
4.5	D	682	44	1270
6	E	802	53	1320
8	F	952	76	1390
10	G	1142	98	1470

This document is the absolute property of R&M Materials Handling, Inc. This document must not be copied without the written permission of R&M Materials Handling, Inc. The contents thereof must not be disclosed to a third party nor be used for any unauthorized purpose. Contravention will be prosecuted.

ETVPH Design	ETVPH Chd	Appd	Ref Drawing	QC-N-08
2005-08-26 Date	TROLLEY; NORMAL HEADROOM			1 of 15 Folder
SLEQDCV Owner Dept	CURVED TRACK, 8 ROPE FALLS			
R&M MATERIALS HANDLING, INC. HOIST & CRANE PRODUCTS	D004209-A			Issue 1