

NORMAL HEADROOM, CURVED TRACK; 6 PART SINGLE
 Hoist type:
 SX4 061...N0

US-60Hz

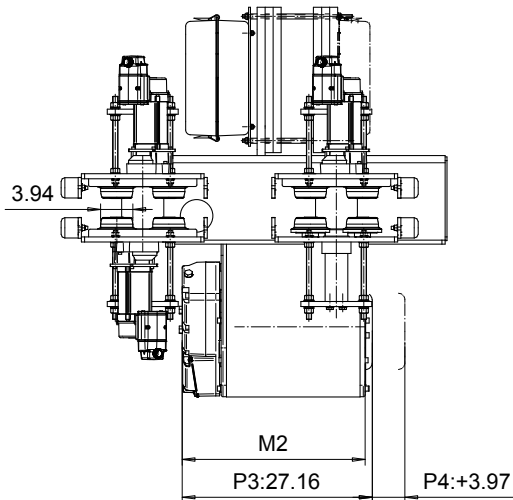
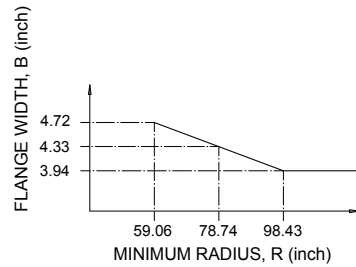
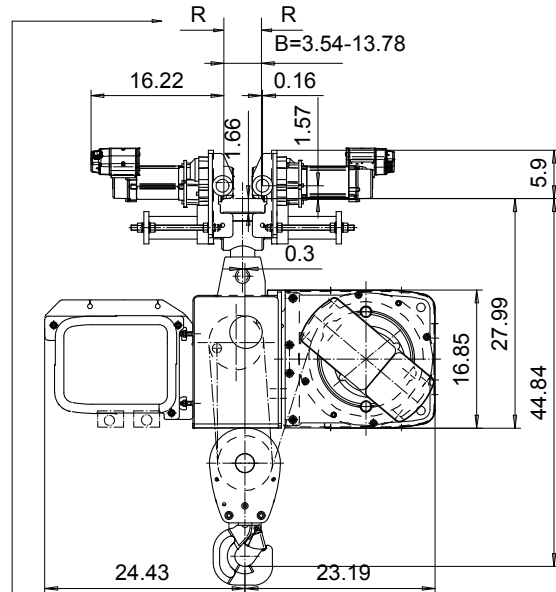
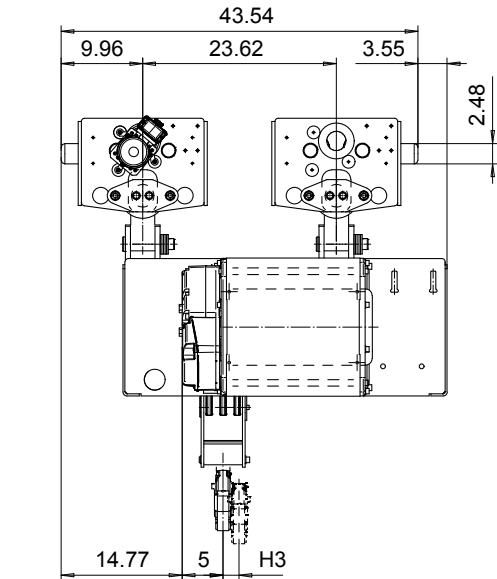

Load (TON)	Class ASME	Hoisting speed (ft/min)	
		Gear+Motor code:	
		F+P3	H+P4
6	H4+	12.5/1.9	20/3.1
7 1/2	H4	12.5/1.9	20/3.1
+ weight (lb):		-	80

HOL (ft)	Length code	M2 (inch)	H3 (inch)	Weight (lb)
19'-8"	C	22.32	1.92	1320
26'-2"	D	26.25	2.55	1360
32'-9"	E	30.98	3.34	1400

This document is the absolute property of R&M Materials Handling, Inc. This document must not be copied without the written permission of R&M Materials Handling, Inc. The contents thereof must not be disclosed to a third party nor be used for any unauthorized purpose. Contravention will be prosecuted.

ETVPH Design	ETVPH Chd	Appd	Ref Drawing	QB-N-06
2004-12-23 Date	TROLLEY; NORMAL HEADROOM			1:10 Folder
SLEQDCV Owner Dept	CURVED TRACK; 6 ROPE FALLS			
R&M MATERIALS HANDLING, INC. HOIST & CRANE PRODUCTS SHEWAN/UNION	D003842-A			Issue 1